

Planning and installation

EcoTouch 5050T

2-power levels (0 % - 50 % - 100 %)



WATERKOTTE GmbH, Gewerkenstraße 15, D-44628 Herne
Tel.: 0049/(0)2323/9376-0, Service: 0049/(0)2323/9376-350
Fax: 0049/(0)2323/9376-99, E-Mail: info@waterkotte.de
Internet: <http://www.waterkotte.de>

Copyright © 2022 by:

WATERKOTTE GmbH

Gewerkenstraße 15, 44628 Herne, Germany



For better readability, the language forms male, female and diverse (m/f/d) are not used simultaneously. All personal terms apply equally to all genders.

All rights reserved. Reproduction, duplication as well as translation of this publication, or excerpts therefrom, require prior written approval by WATERKOTTE GmbH.

Illustrations and diagrams serve as explanatory description and shall not be used as drawings for construction, offers or installation.

All specifications comply with the state of technology at time of printing; we reserve the right to make changes that serve technical progress.

This publication has been prepared with all reasonable care. WATERKOTTE GmbH does not assume any liability for remaining errors or omissions, or for possible damages.



Note: This symbol mark applies only to countries within the European Union (EU).

This symbol mark is in compliance with Directive 2012/19/EU, Article 14. The product has been designed and manufactured with high-quality materials and components which are suitable for recycling.

This symbol means that electrical and electronic equipment, at the end of its useful life, shall be disposed of separately from household waste. Please dispose of this equipment at your designated collection point or local recycling centre.

In the European Union, different collection systems are available for used electrical and electronic equipment. Please help us to conserve the environment we live in!

NOTICE

Do not release R410A into the atmosphere:
R410A is a fluorinated greenhouse gas according to Kyoto Protocol and has a global warming potential (GWP) of 2088.

Content

1	Safety	5
1.1	Intended use.....	5
1.2	Basic safety precautions.....	5
1.2.1	Keep information available	5
1.2.2	Before initial use.....	5
1.2.3	Environmental protection	6
1.2.4	Modifications and repairs on the heat pump	6
1.3	Hazards.....	6
1.4	Specific types of hazards.....	8
1.5	Operator's duty of care.....	8
1.6	Other applicable documents.....	8
2	Functional principle of heat pump	9
3	Product description	10
3.1	Overview.....	10
3.2	Overview (unit opened)	11
4	Components and installation	12
4.1	Heating system EcoTouch 5050T	12
4.2	Installation	12
4.2.1	Heat pump system series EcoTouch 5050T	12
4.2.2	Heat pump module.....	12
4.3	Electrical equipment	13
4.3.1	Electronic heat pump control	13
4.3.2	Sensors	13
4.3.3	COP counter.....	13
4.4	Options.....	13
5	Transport	14
5.1	Transport to installation site	14
6	Installation	15
6.1	Environmental conditions for installation	15
6.2	Creating the foundation and installing heat pump	16
6.2.1	Laying a foundation for acoustic heat pump	16
6.3	Installation of the housing	17
6.3.1	Removing the housing	17
7	Installation and connection	18
7.1	Connections EcoTouch 5050T (rear side).....	18
7.2	Connection to heating system	18
7.2.1	Heat pump with underfloor heating	19
7.2.2	Heat pump with radiators (no cooling mode).....	19
7.2.3	Heat pump with swimming pool.....	20
7.3	Connection to heat source	20
7.3.1	Water glycol systems.....	20
7.3.2	Groundwater heat source	20
7.3.3	Flow monitoring	22
7.3.4	Groundwater installation: Separating heat exchanger	24
8	Electrical work	25
8.1	Electrical installation.....	25
8.2	Installation instructions for external sensor.....	26
8.3	Cabeling	26
8.4	Cable list.....	27

8.5	Electrical connections	28
8.6	Controller WWPR 2	29
8.7	Connectors.....	30
9	Pipe & instrumentation / measurement & control technology	31
10	Commissioning	32
10.1	Pre-startup checks	32
10.2	Initial start-up of heat pump	34
10.3	Control of entire operation	35
10.4	Turning heat pump off	35
10.5	Taking heat pump out of operation for extended period	35
11	Troubleshooting	36
11.1	Possible faults and solutions	36
11.1.1	Fault at input side (LP fault)	36
11.1.2	Fault at output side (HP fault)	36
11.1.3	Fault in circulation pumps	36
11.1.4	Fault in compressor motor	36
12	Safety measures	37
12.1	Pressure limits of compressor.....	37
12.2	Motor protection against excessive temperature	37
12.3	Refrigerator oil	37
13	Maintenance and care	38
14	Connection diagrams	39
14.1	Heat pump EcoTouch 5050T with underfloor heating system, without single room control	39
14.2	Heat pump EcoTouch 5050T with underfloor heating system and single room control	40
14.3	Heat pump EcoTouch 5050T with underfloor heating system, without single room control, with hygienic hot water heating	41
14.4	Heat pump EcoTouch 5050T ground water or ground – with connection accessory F10815 (option)	42
14.5	Heat pump EcoTouch 5050T ground water or ground – with connection accessory F10815 (option)	43
14.6	Description of the parts in the connection diagram	44
15	Technical data	46

1 Safety

1.1 Intended use

Your WATERKOTTE heat pump is used for space heating and cooling, and heating of domestic water.

Project planning of the heat source system must be performed in compliance with the technical information provided by WATERKOTTE for layout of heat source systems.

Heat pump shall only be turned on after the refrigerant connections are completely filled, and the other hydraulic circuits are completely filled and vented, and all electrical connections are properly completed.

WATERKOTTE generally indicates the sound power level according to DIN EN 12102 as the sound value. Peaks can occur in certain frequency ranges due to operation. These can be both high and low tones. As long as the sound pressure level is plausible in relation to our specified sound power levels, these noises are generally harmless and are not a defect.

Commissioning may only be carried out by trained professionals. Damages caused by non-compliance with above mentioned items are not covered by the warranty (see enclosed Exclusion of Warranty).

1.2 Basic safety precautions

1.2.1 Keep information available

In addition to the operating manual, also furnish operating instructions in terms of Labour Protection Law and Work Equipment ordinance. Keep all safety and operating signs on the heat pump in fully legible condition at all times. Replace damaged or illegible signs immediately.

1.2.2 Before initial use

Before initial use of your WATERKOTTE heat pump, familiarise yourself with:

- Operating and control elements of your WATERKOTTE heat pump
- Equipment of heat pump
- Operation of heat pump
- Immediate surroundings of heat pump
- Safety devices of heat pump

Before initial start, perform the following work:

- Ensure that all safety devices are installed and function as intended.
- Check heat pump for visible damage. Remedy any detected defects immediately.
Heat pump must be in perfect condition during operation!
- Ensure that only authorised personnel stay in the work area of the heat pump and that no other persons are endangered when heat pump is started.
- Remove all objects and other materials that are not required for operation of the heat pump from the work area of the heat pump.

1.2.3 Environmental protection

- Observe the regulations regarding waste avoidance and proper waste recycling or disposal when performing any kind of work on and with the heat pump.
- Ensure that particularly during installation and maintenance work, as well as when placing out of operation, pollutants such as grease, oil, refrigerant, solvent- containing cleaning fluids, etc. do not contaminate the ground or enter the sewer system!
These materials must be collected, stored, transported and disposed of in appropriate containers.

1.2.4 Modifications and repairs on the heat pump

For safety reasons, no unauthorised modifications shall be performed on the heat pump.

Thus, all intended modifications are subject to written approval by WATERKOTTE.

Use only original spare parts from WATERKOTTE.

Original spare parts are specially designed for your heat pump. Externally procured parts provide no guarantee that they are designed and manufactured in compliance with relevant usage and safety requirements.

Parts and special equipment not delivered by WATERKOTTE are not approved for use on the heat pump.

1.3 Hazards

Observe the following points to avoid life-threatening injuries and damages to the heat pump during operation:



Warning! Risk of electric shock!

Do not use water or other liquids to clean the unit!

Keep all electrical supply units locked at all times!

Any work on the electrical equipment of the heat pump shall only be performed by professional electricians!



Discharging refrigerant can cause severe personal injury (suffocation or hypothermia)!

Avoid contact with refrigerant!

Note the minimum volume of the installation room and consider the type of the refrigerant (EN 378-1).



Warning! Risk of suffocation!

The packaging is not a toy! The packaging must be disposed of environmentally acceptable.

! WARNING**Risk of burns!**

During operation, surface temperatures (compressor and pressure line) can climb above 100 °C or drop below 0 °C.

Do not remove housing cover during operation!

Allow heat pump to cool down before removing cover.

! WARNING**Risk of injury!**

Risk of chemical burns: when skin has a direct contact with lubricant leak.

Wear suitable clothing when performing maintenance work on the heat pump!

! WARNING**Risk of injury in case of leakage in cooling circuit!**

Skin contact with refrigerant may cause freezing of tissue and frostbites. High vapour concentrations can cause headaches, dizziness, fatigue, nausea and even unconsciousness. Irregular heartbeat (arrhythmia).

Avoid contact with refrigerant! Do not expose to heat, sparks, naked light or other ignition sources!

NOTICE**Electrostatic charge!**

Electronic components can be damaged by electrostatic processes.

Ground yourself before touching electronic components.

NOTICE**Risk of total loss!**

Repeated restart of heat pump can result in total loss!

In case of heat pump failure, before restart an inspection by qualified and authorised personnel must be performed.

NOTICE

Due to test bench operation, the heat pump can have ethylene glycol residues.

1.4 Specific types of hazards

To avoid damage to heat pump or life-threatening injuries during installation of heat pump, the following points must be observed:

- Heat pump parts that are improperly placed or incorrectly attached can fall down or overturn.
- Sharp-edged heat pump parts that are still exposed and accessible can result in injury.
- Incorrectly installed lines (e.g. insufficient bending radius) can cause smouldering and cable fires.
- Risk of chemical burns when skin comes in direct contact with lubricant leak.
- Electronic components can be damaged by electrostatic processes.
- During operation, surface temperatures (compressor and pressure line) can climb above 100 °C or drop below 0 °C.
Serious burns/frostbites can occur. Before working on the compressor:
Switch off unit and allow to cool down.

1.5 Operator's duty of care

Your WATERKOTTE heat pump has been designed and built on the basis of a risk analysis and after careful selection of standards to be observed. Thus, your heat pump is state-of-the-art and provides for maximum safety. In practice, however, this safety can only be ensured by taking all necessary measures. As operator of the heat pump it is your responsibility to plan these measures and oversee their implementation.

You must ensure that:

- The heat pump is only used as intended (see also chapter 1.1, „Intended use“).
- The heat pump is only operated in perfect, fully functional condition and safety devices are checked regularly to ensure that they are working properly.
- The operating manual is available in perfect condition at the heat pump at all times.
- The heat pump is operated, maintained and repaired only by adequately qualified and authorised personnel.
- None of the safety and warning notices on the heat pump are removed or damaged.

1.6 Other applicable documents

- Operating manual: WWPR WATERKOTTE heat pump controller.

2 Functional principle of heat pump

The heat pump is used to produce thermal energy for space heating and, if required, domestic water heating. The medium used as heat source (WQ) is the ground.

It is also possible to cool a building.

To utilise ground as thermal energy, for domestic water heating and cooling in your home, you need the following:

- a heat source (borehole with geothermal energy probes or groundwater extraction / discharge)
- heating system EcoTouch 5050T
- domestic hot water tank

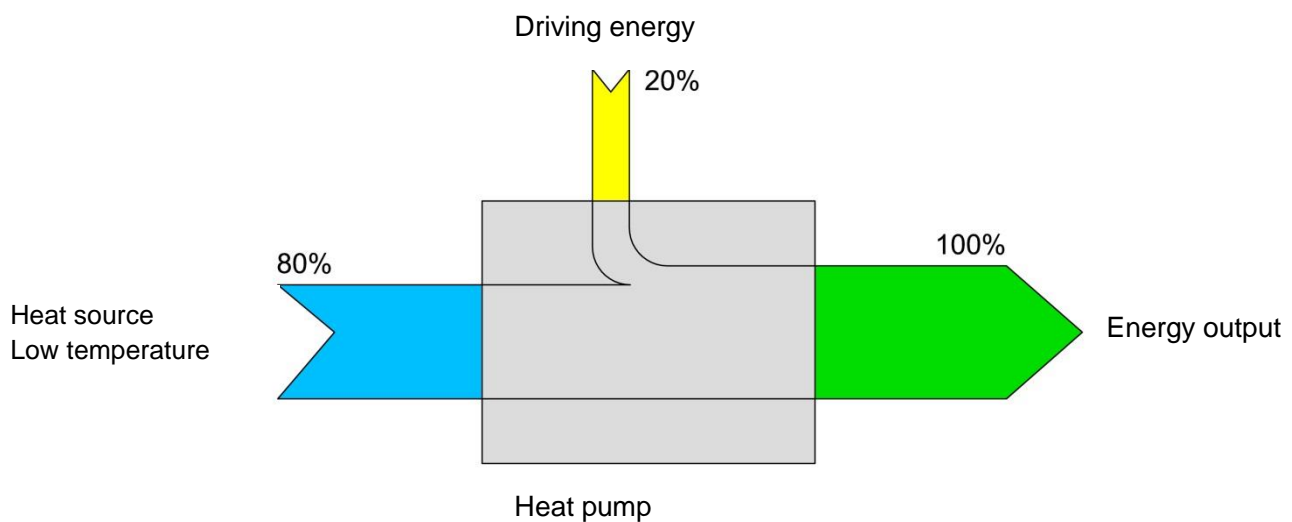

Figure 1: Energy share when using a geothermal energy pump

3 Product description

3.1 Overview



1	ON / OFF push-button switch (control)
2	Control panel (electronic heat pump controller)

3.2 Overview (unit opened)

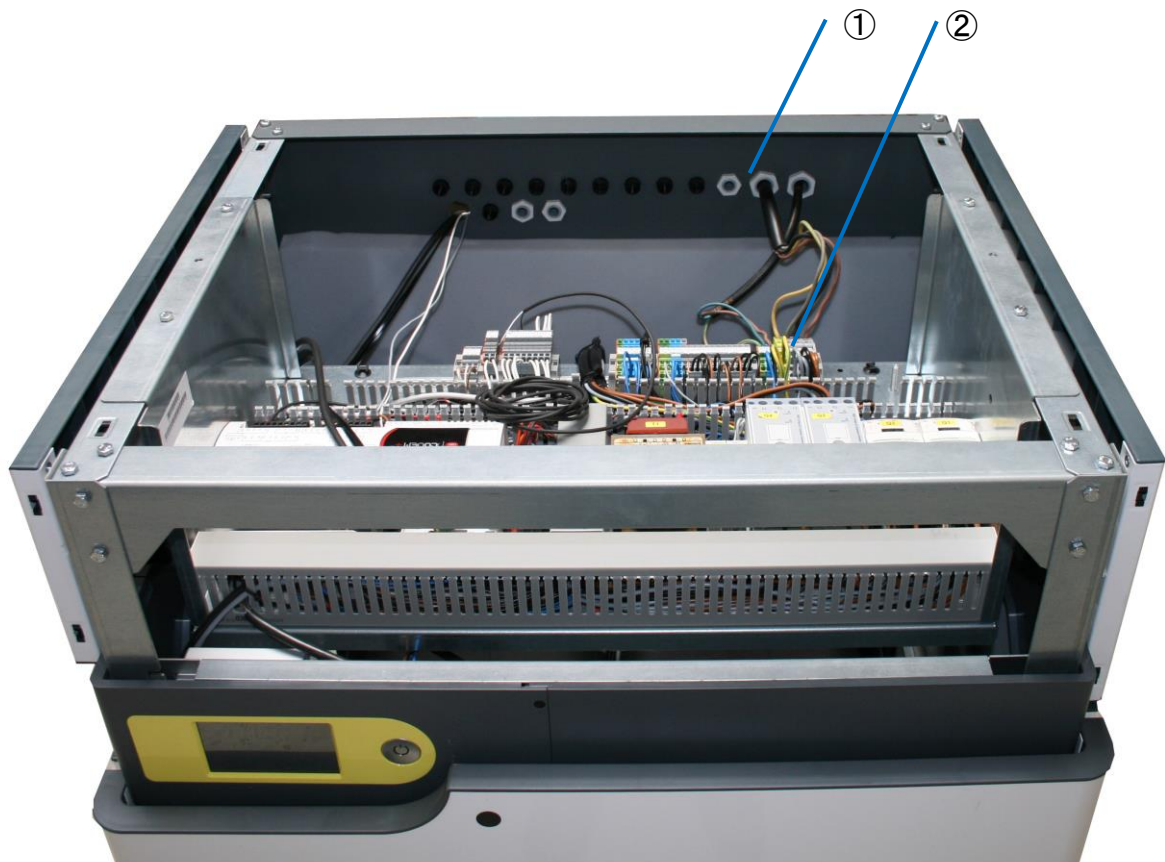

Illustration 3: EcoTouch 5050T (top view, opened)

1	Safety group with manometer: relief valve, bleeder
2	Connection terminal

4 Components and installation

4.1 Heating system EcoTouch 5050T



All components of the heating system are mounted in a protective steel plate housing which is intended for installation inside. The base frame consists of a bent, thick-walled sheet steel. Together with the rear panel frame, which also consists of a thick-walled sheet steel, it forms a unit. Side panels, cover, front and the tilt-mounted, ergonomic control panel can be removed.

All housing parts are available in high-gloss white. Sound insulation ensures low noise emissions.

4.2 Installation

4.2.1 Heat pump system series EcoTouch 5050T

The heat pump is designed as complete operational unit for thermodynamic space heating, expandable to domestic hot water production.

Functions: Heat pump, domestic hot water heating system, natural cooling (option), regulation and electrical control.

All dynamic components are located on an internal chassis (dual chassis construction), separated from the external housing. The pipe joints between internal and external chassis are flexibly mounted to prevent structure-born noise transmission within the unit.

4.2.2 Heat pump module



The series 5050T is provided with two compressors (power level: 50 % or 100 %). The compressors feature a fully hermetic design in approved leading scroll technology (fig. left). Evaporator and condenser are designed as soldered stainless steel plate packs with reverse flow circuits, according to state-of-the-art development, tailored to the new non-flammable safety refrigerants that will be required by law in the future. In combination with ester oil (biodegradable), this guarantees optimum lubrication conditions, low friction losses and therefore the highest possible life expectancy for the compressor according to the latest industrial research findings.

The cooling circuit is designed in accordance with the relevant safety regulations. Manufacturing quality is carried out based on ISO 9000ff, supplemented by an automated computer-monitored quality test (pressure stress and helium leak test) in addition to inspection of all parameters in a subsequent trial run.

4.3 Electrical equipment

The electrical connections are made via the internal terminal (on the construction profile). The implementation of the electrical cable is carried by the rear wall (with the strain relief).

The internal terminal connects the entire sensor, all queries, all relay outputs, digital circuit, the compressor and the electrical heating element. The WATERKOTTE WWPR-controller is supplied with a control panel mounted on the 24 V AC transformer.

4.3.1 Electronic heat pump control

The heat pump control (control panel is pictured) is included in the scope of delivery of the WATERKOTTE heat pump.

Use in other than WATERKOTTE heat pumps will void any warranty claim. The control is used to control and monitor heating systems that are operated with WATERKOTTE compact heat pumps according to technical guidelines of WATERKOTTE Wärmepumpen GmbH.

The following tasks are performed: everything to do with regulation (depending on the external temperature with pilot room guidance), control, monitoring, self-diagnosis, saving of data in cases of breakdown.

NOTICE

WATERKOTTE explicitly states that function warranty will become void if used on systems not approved by WATERKOTTE. Any liability for consequential damages due to incorrect function within these systems shall be explicitly excluded.

Info: Technical details, operation and warning messages (see *Operating manual for Heat pump control*).

4.3.2 Sensors

The control's sensor system consists of: Pressure transmitter for evaporation and condensation pressure/temperature, 5 sensors for temperature detection in all circuits. External wall sensor (accessories kit). Pilot room sensor and hot water sensor: optional.

4.3.3 COP counter

A WATERKOTTE COP counter is already integrated in the heat pump control. For additional information, please refer to *Operating manual for Heat pump control*.

4.4 Options

Domestic hot water production (heating-side vertical tank, hot water heater, temperature sensor, three way valve), pilot room sensor, natural cooling, WEB interface: for control and parameterization of the heat pump via internet.

5 Transport

- Exercise particular caution when transporting the units. Since the unit weighs 232 kg or more, at least two people are required for transport. Do not use the packaging straps to carry the unit. Wear protective gloves for unpacking and transporting the unit to prevent hand injuries from cooling fins or other parts.
- Observe the transport information on the packaging.
- Observe the specified storage requirements.
- The units may not be stacked.
- Heat pump may only be lifted at the provided attachment points.
- Heat pump may only be transported in upright position.
- Ensure proper disposal of packaging materials. Packaging materials, such as nails or other metal or wooden parts, may cause injuries.
- Please also read chapter "General safety information".

5.1 Transport to installation site

Units of the EcoTouch 5050T series are delivered ready-to-connect with separate metal cladding. For transport purposes, the metal cladding and the heat pump are delivered in one carton on a palette. During transport it must be ensured that appropriate means of transport are used (lift truck, transport rollers, handcart).

Unit must be transported upright!

Transport in tilted position (45°) is permitted only temporarily during insertion.

Horizontal transport results in oil displacement in compressor and can cause damage during start-up.

NOTICE

After packaging is removed or opened it is not permitted to tilt the unit by applying pressure to the pipelines or housing enclosure; this could result in bent housing parts and pipelines.

6 Installation

- Installation of the heat pump must be performed on a flat and horizontal surface.
- The unit should not be installed on a floating screed (structure-born noise).
- We recommend a concrete base.
- Wall clearance left, right and on top must be at least 300 mm.
- Wall clearance in rear must be at least 300 mm.
- Wall clearance in front: at least 1,000 mm.

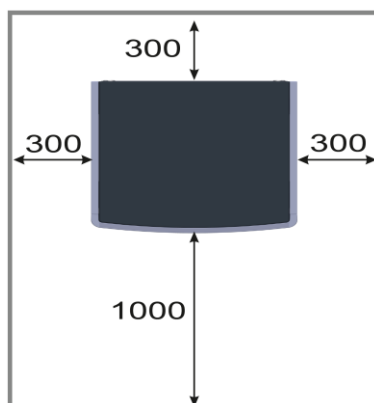

6.1 Environmental conditions for installation

Note the minimum volume of the installation room and consider the type of the refrigerant (EN 378-1).

The room must be dry. Room temperature should be between +5 °C and +25 °C.

To facilitate maintenance, the use of a base plate is recommended. The housing frame is to be completely supported. If support is only provided at points, operating noise increases. To compensate for minor unevenness, we recommend use of an approx. 10 mm thick rubber mat. Acoustics in installation rooms with rigid walls can noticeably increase operating noise.

Counter measure: acoustic insulation of one of the opposite wall or ceiling surfaces.

6.2 Creating the foundation and installing heat pump

- with best possible structure-borne noise insulation

6.2.1 Laying a foundation for acoustic heat pump

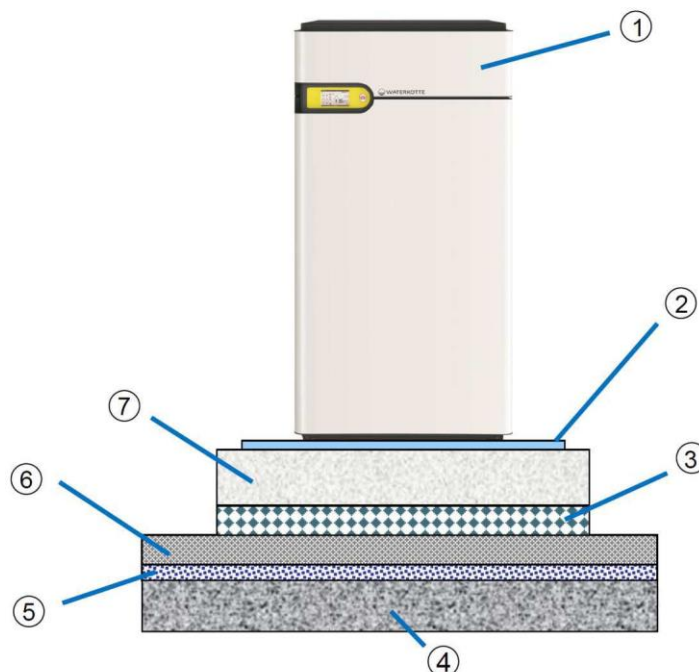

1	Heat pump
2	Noise-absorbent mat Polyethylen (PE)
3	Insulation material (3 layer, polyurethan rubber)
4	Supporting subsurface
5	Insulation material
6	Screed
7	Concrete plinth

Dimensions concrete plinth (mm):

Plinth	Width	x	Depth	x	High
EcoTouch 5050T	850 mm		700 mm		150 mm

6.3 Installation of the housing

To avoid damage, the delivered housing parts are not installed.

After preparation of all connections, mount the housing parts to the intended positions (insert and press).

6.3.1 Removing the housing



A disassembly tool is delivered with the heat pump. Use this tool to avoid damage while you are removing the housing parts.



Procedure:

- Keep enough clearance with the tool to the upper and lower metal edge. So you can't damage the retaining bolts (see Figure).
- The removal tool is driven with moderate force, by hand, into the gap between the front and side panel.

7 Installation and connection

7.1 Connections EcoTouch 5050T (rear side)

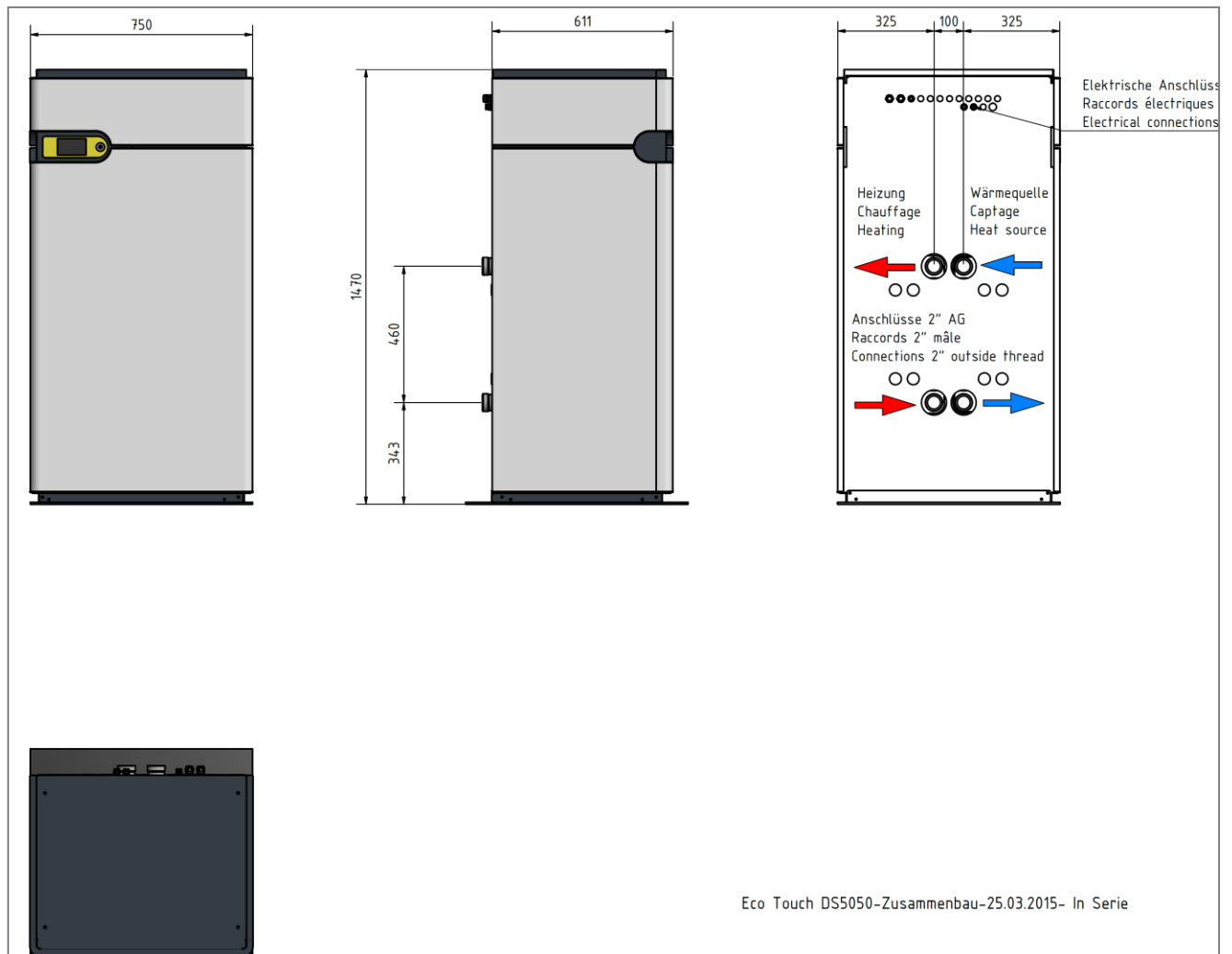

Figure 4: Connections EcoTouch 5050T heating and heat source (2" flat sealing)

7.2 Connection to heating system

The connected systems should be technically clean and free from air. **Steel pipes** and other **steel components** in the water circuit shall **not be used** when connecting diffusion-open surface heating system. In exceptional cases an effective corrosion inhibitor must be added and a dirt trap (0.8 mm mesh) connected before entry into the unit.

The system must then be marked accordingly and the maintenance instructions of the supplier must be followed strictly. Designation for inlet and outlet must be observed. When there is danger of frost, add antifreeze to protect against formation of ice.

To ensure tension-free connection of the heat pump, a flexible connection is required!

Tip:

We recommend the use of external shut-off devices (ball valves) at all con-

nections. Thus, if service is required, only the minimum amount of heat transfer medium has to be drained from the system and time-consuming venting measures can be avoided.

In factory default setting, the pipe ends are closed with plastic caps. When connection is performed, these caps must be removed and the connecting unions screwed on with suitable gasket.

To tighten the screw connections, resistance at the cap must be provided with suitable tool!

NOTICE

To prevent corrosion and scale formation in the heating system (circulating pumps, radiators, etc.), the heating water must be treated according to VDI 2035 (e.g. with corrosion inhibitor).

- To find the volume flow at heating side for the corresponding heat pump, please refer to the performance table (**5K spread**).
- The heating connections (2") feature an external pipe thread for flat-sealing connections with union nut and insert.
- A circulation pump is installed at heating side. The circulation pumps are offered with an internally coated housing (plastic).

7.2.1 Heat pump with underfloor heating

- The use of steel pipes and other steel components is not permitted in the heating circuit of underfloor heating systems. Use stainless steel, copper, brass or plastic - such as PE - for instance.
- In case of single room control, a buffer tank (corrosion-free) and a differential pressure overflow valve must be installed in the heating system (see diagrams).
- When the living space controlled by single room control is less than 1/3, a buffer tank is not required if the remaining 2/3 floor circuits remain open.

7.2.2 Heat pump with radiators (no cooling mode)

- On systems with steel radiators an effective corrosion inhibitor must be added and a dirt trap (0.8 mm mesh) connected before entry into the unit. The system must then be marked accordingly and the maintenance instructions of the supplier must be followed strictly.
- Heating systems with radiators require the installation of a buffer tank (connected in parallel) (see diagrams). The size of the tank must be calculated. The heat pump control regulates the temperature of the buffer tank. After the tank, the components (circulation pump, mixing valve ...) must be controlled with an optional WATERKOTTE mixing control (P11108).
- If the formation of deposits is to be expected (e.g. strong contamination) based on water quality, cleaning must be performed in regular intervals. Cleaning can be performed by flushing.

Procedure:

The plate heat exchanger is to be flushed with a suitable cleaning agent in counter-flow direction. If chemicals are used for cleaning, please ensure that they are compatible to stainless steel, copper or nickel. Failure to comply can result in destruction of plate heat exchanger!

7.2.3 Heat pump with swimming pool

(only possible with additional electrical module)

The following components are required for heating a swimming pool:

- 1x 3-way motor ball valve (Z20638).
- 1x swimming pool sensor with immersion sleeve (Z14783 and Z13344).
- 1x swimming pool upgrade kit (P11108, P11159 or P11225).

7.3 Connection to heat source

The following can be used as heat source:

- **The ground:** by connection to a horizontal geothermal absorber (e.g. PE-pipe 20x2) or a vertical geothermal absorber (geothermal probes).
- **The groundwater:** by connection to a well system, using an accessories kit available from WATERKOTTE to monitor the flow at heat source side and separation heat exchanger (heat source side).
- The layout of the heat source system must be according to the WATERKOTTE dimensioning information.
- Refer to the performance table to find the volume flow for the corresponding heat pump.
- The heat source connections (2") feature an external pipe thread for flat-sealing connections with union nut and insert.
- A pressure expansion tank has to be installed on site.
- A circulation pump has to be installed on site.
- One safety fitting (air diverter / filling pressure gauge / safety valve has to be installed on site.
- In case of water glycol systems, it is not permitted to use steel pipes and other steel components in the water circuit. Use stainless steel, copper, brass or plastic - such as PE - for instance. Steel pipes and other steel components should also be avoided in groundwater systems.

7.3.1 Water glycol systems

To prevent frost damage, the heat source system must be filled with about 30 % WATERKOTTE ethylene glycol (freezing point at about -15 °C). The heat source system must be properly filled with the operating media and vented.

7.3.2 Groundwater heat source

For groundwater heat pumps the installation of a separation heat exchanger is absolutely essential to avoid direct damage to the heat pump. The intermediate circuit must be filled with about 15 % ethylene glycol. The following WATERKOTTE accessories are required for groundwater application:

- Filter
- Flow monitoring
- Separating heat exchanger

7.3.2.1 Groundwater quality

When using groundwater, the following limits (see table and diagram) must be observed. If limits are exceeded, a separation heat exchanger is used. The soldered plate heat exchanger consists of embossed stainless steel plates 1.4401 or AISI 316. You must therefore take the corrosion behaviour of stainless steel and the solder material, copper, into account.

Water contents and properties	Unit	Copper-soldered plate heat exchanger (standard)	Nickel-soldered plate heat exchanger (optional)
pH value		7 - 9 (incorporating SI Index)	6 - 10
Saturation index SI (delta pH value)		-0.2 < 0 < +0.2	No specification
Total hardness	°dH	6 - 15	6 - 15
Conductivity	µS/cm	10...500	No specification
Filterable matter	mg/l	< 30	< 30
Chlorides	mg/l	See diagrams on next page. No chlorides permitted above 100 °C.	
Free chlorine	mg/l	< 0.5	< 0.5
Hydrogen sulphide (H ₂ S)	mg/l	< 0.05	No specification
Ammonia (NH ₃ /NH ₄ ⁺)	mg/l	< 2	
Sulphate	mg/l	< 100	< 300
Hydrogen carbonate	mg/l	< 300	No specification
Hydrogen carbonate / sulphate	mg/l	> 1.0	No specification
Sulphide	mg/l	< 1	< 5
Nitrate	mg/l	< 100	No specification
Nitrite	mg/l	< 0.1	No specification
Iron, dissolved	mg/l	< 0.2	No specification
Manganese	mg/l	< 0.1	No specification
Free aggressive carbon dioxide	mg/l	< 20	No specification

Table 1: Resistance of soldered plate heat exchangers to corrosion by substances contained in water

The values listed are guidelines which may vary under certain operating conditions. If you have questions, please call us under Tel. : (+49) (0) 23 23 / 9 37 60

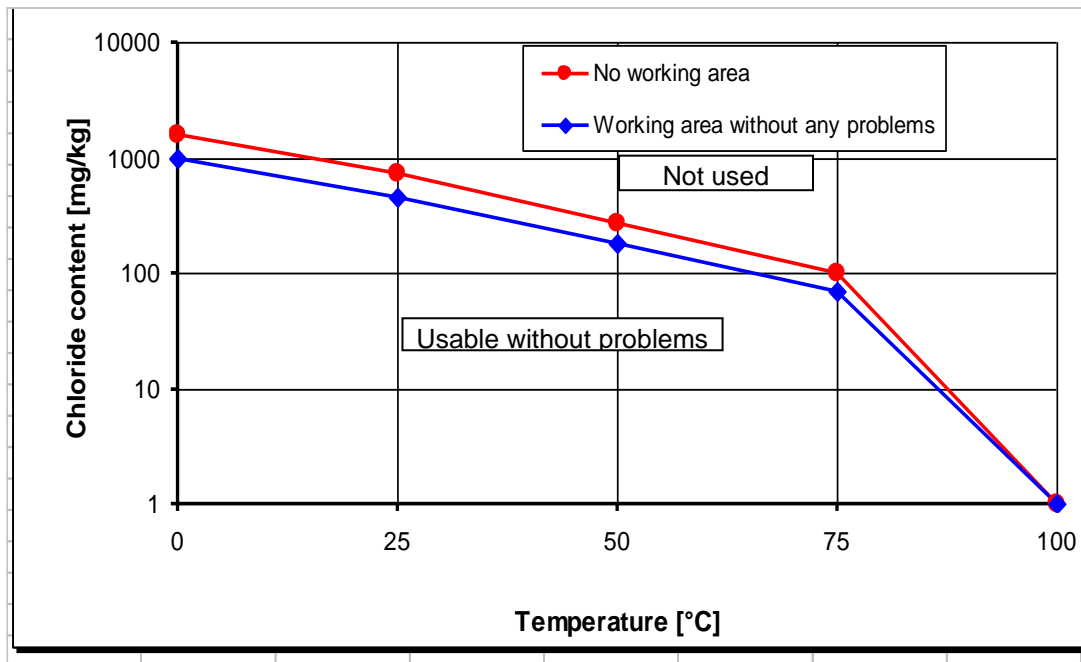

Permitted chloride content depending on the temperature

7.3.3 Flow monitoring



When using water as heat source, the evaporator of the heat pump can be destroyed by ice formation due to lack of water (frost damage). Repeated switching on of heat pump in an improper forced manner may easily result in total loss. For this reason, we specify a reliable protective measure against lack of water. The protective measure consists of two devices that function independently of one another:

- a) Temperature limit by controller: For this purpose, the controller is configured for operating mode "Heat source water" This solution allows that:
 - a warning is generated if value drops below +1 °C and
 - operation is interrupted when value drops below -1 °C.

- b) Because the measure mentioned under a) cannot react quick enough in case of sudden lack of water, an additional low water safety device must be provided.

A low water safety device consists of a float-type volume display with adjustable limit indicator (limit indicator is a Reed contact).

Function:

The heat pump control switches the compressor on with a time delay to "pump heat source". The start of the compressor is only enabled if the minimum water volume is present during the lead time and the limit indicator did not respond. This device remains active during the entire operation of the heat pump. If water volume drops below the permissible level during operation, the heat pump is shut down. This device provides maximum se-

curity because it virtually covers all risks, such as filter contamination, evaporator contamination, overloaded well, etc.

Damages caused by freezing of evaporator result in exclusion of warranty!

Heat pump	Optimized volume flow in l/h when ground water is 10 °C / 6 °C ($\Delta t=4K$)	Min. volume flow in l/h when ground water is 10 °C / 4 °C ($\Delta t=6K$)
EcoTouch 5028.5	5000	3300
EcoTouch 5034.5T	6200	4134
EcoTouch 5045.5T	8100	5400
EcoTouch 5056.5T	10100	6734

Table for setting the limit contact at 10 °C inlet temperature. The volume flow corresponds to a cooling of 6K.

The volume flow has to be increased at a lower inlet temperature (< 10 °C). The outlet temperature of the heat pump should not fall below a value of 4 °C!

7.3.3.1 Filter

To prevent contamination, the media inlets of the evaporator and heat exchanger must be equipped with a filter (0.8 mm mesh). Contamination in the heat exchanger can cause corrosion and - in some applications - freezing of the heat exchanger.

7.3.3.2 Cleaning

If the formation of deposits is to be expected (e.g. severe contamination) based on water quality, cleaning must be performed in regular intervals. Cleaning can be performed by flushing. The plate heat exchanger is to be flushed with a suitable cleaning agent in counter-flow direction.

NOTICE

If chemicals are used for cleaning, please ensure that they are compatible with stainless steel or copper. **Failure to comply can result in destruction of plate heat exchanger!**

7.3.4 Groundwater installation: Separating heat exchanger

NOTICE

For groundwater heat pumps the installation of a separation heat exchanger is absolutely essential to avoid direct damage to the heat pump. The intermediate circuit must be filled with about 15 % ethylene glycol.

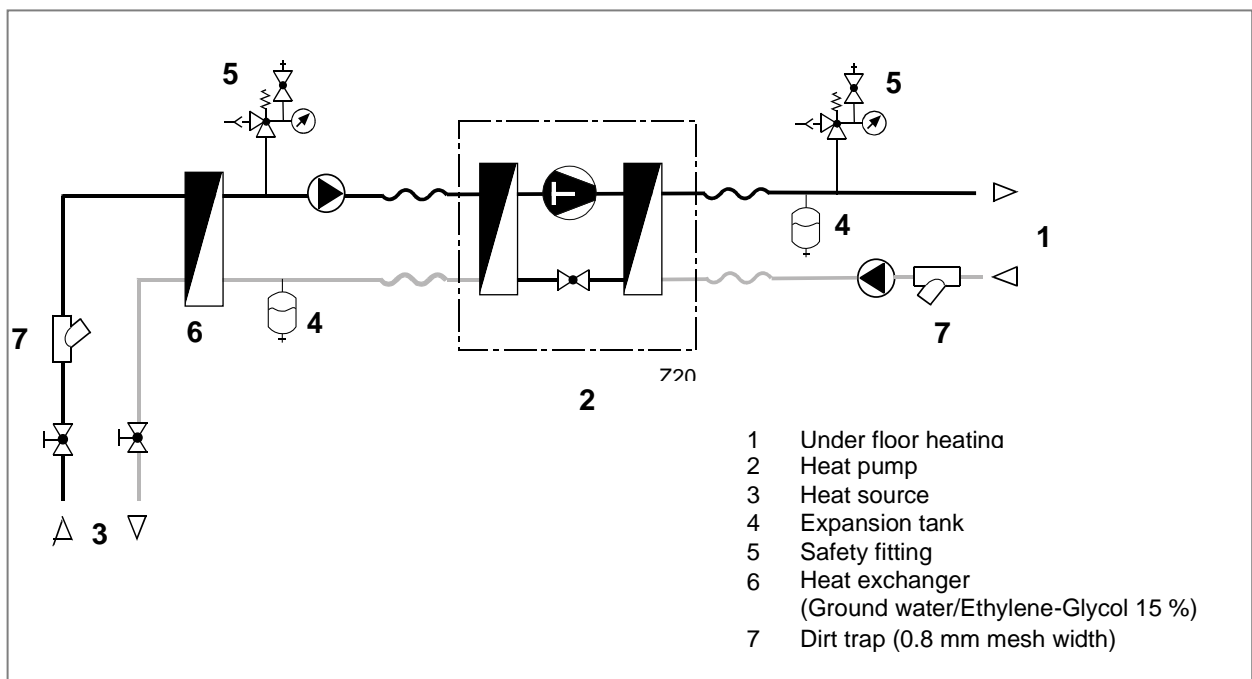

8 Electrical work



Before carrying out electrical work:

- Warning! Risk of electric shock!
Install circuit breakers for personal protection.
- Any work on the electrical equipment of the heat pump shall only be performed by professional electricians!
- For the power lines, use standard cables of sufficient capacity. Otherwise there is a risk of short circuits, overheating or fire.
- When installing power lines, do not apply tension to the cables. Loosened connections pose a risk of cables slipping from terminals or breaking; this can result in overheating or fire.
- Should it be necessary, disconnect all feed lines from the house fuse box.

8.1 Electrical installation

Follow the wiring diagram!

The installation must be performed by an accredited professional. He is also responsible for the proper installation according to regulations and initial commissioning.

For electrical installation, the regulations of VDE/EN as well as of EVU must be observed.

For wiring, standard lines must be used.

Main connection cable, if not connected to fixed installation:
Type H05VV-F.

Connection cables 230 / 400 V and remote cables / sensor cables must be installed with separate cables.

Minimum diameter of connection cables 1.5 mm².

Attention: Terminals in connection terminal max. 4 mm². Vacant terminals may not be used as support terminals for additional wiring.

Please note:

- All plug connections used in the heat pump control may **not be connected or disconnected under voltage** – disconnect mains voltage.
- Before accessing connection terminals, **all power supply circuits** must be interrupted.
- The relay circuit board (WWPR) may only be connected or removed by **professionals**.
- Install and remove relay circuit board only in **voltage-free state**.
- All connections performed directly at the plug connections of the control board must be established with **flexible lines**; if necessary, intermediate terminals must be used.
- Install a residual current circuit breaker (the technical specifications are

provided by your electrical supply company).

- Replacement of mains connection cables may only be performed by customer service or a similarly qualified person.

NOTICE

Shutdown by electrical supply company! Danger of total loss!

Switching off the control voltage leads to an unregulated process in the system.

A regulated shutdown by the electric supply company has to be done via the SG Ready A input. Here, the heat pump switches off according to a defined process.

8.2 Installation instructions for external sensor

The **external sensor** must always be installed vertically (even if temporary), with cable entry pointing downward. Next, screw connection must be tightened enough to allow sealing insertion of cable and to prevent water from entering the housing.

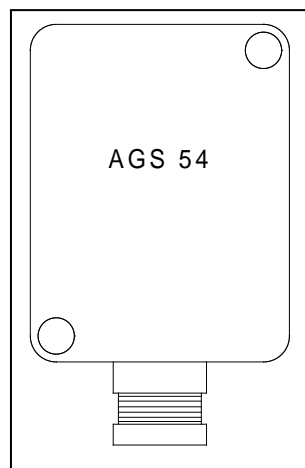

Figure 5: Installation position of external sensor

8.3 Cabeling



The cable for the electric wiring can be passed through the openings to the upper rear wall of the heat pump.

The cables are fixed by means of strain relief and cable glands.

8.4 Cable list

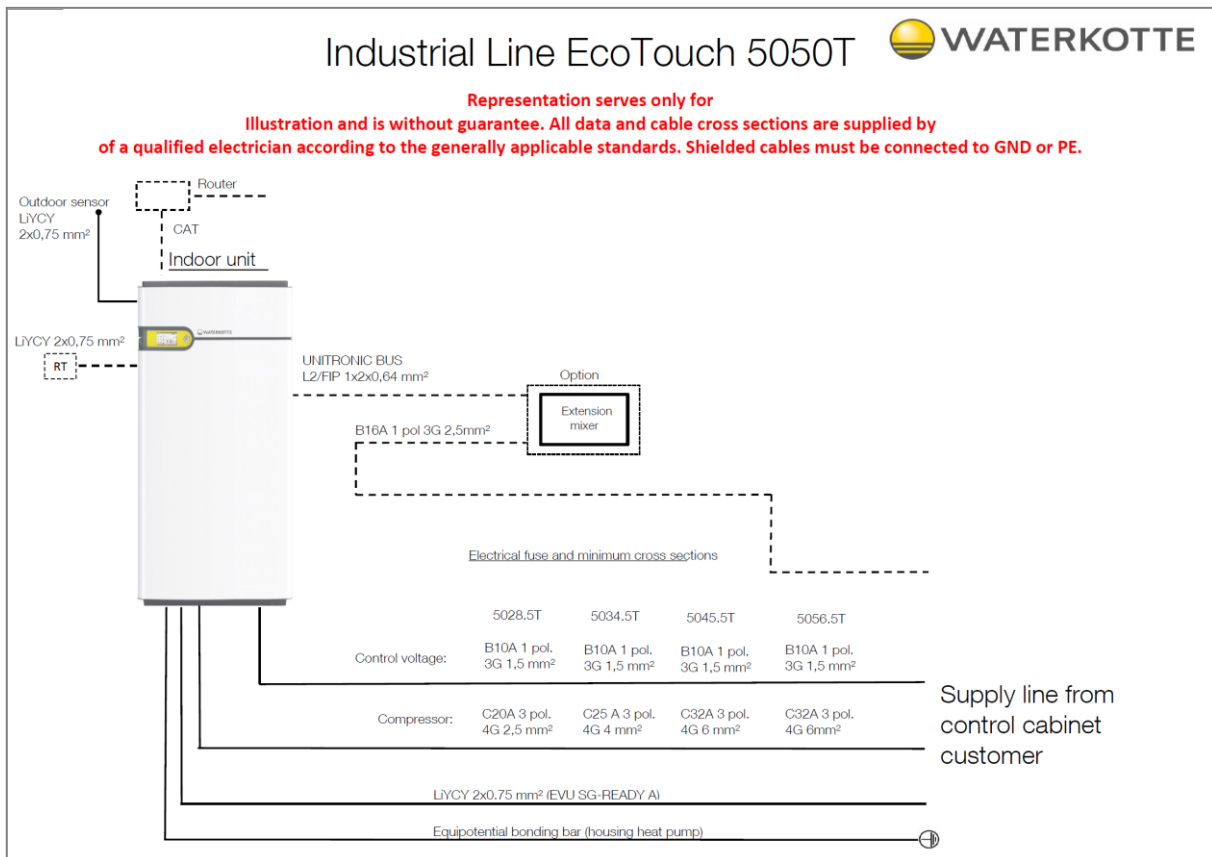

8.5 Electrical connections

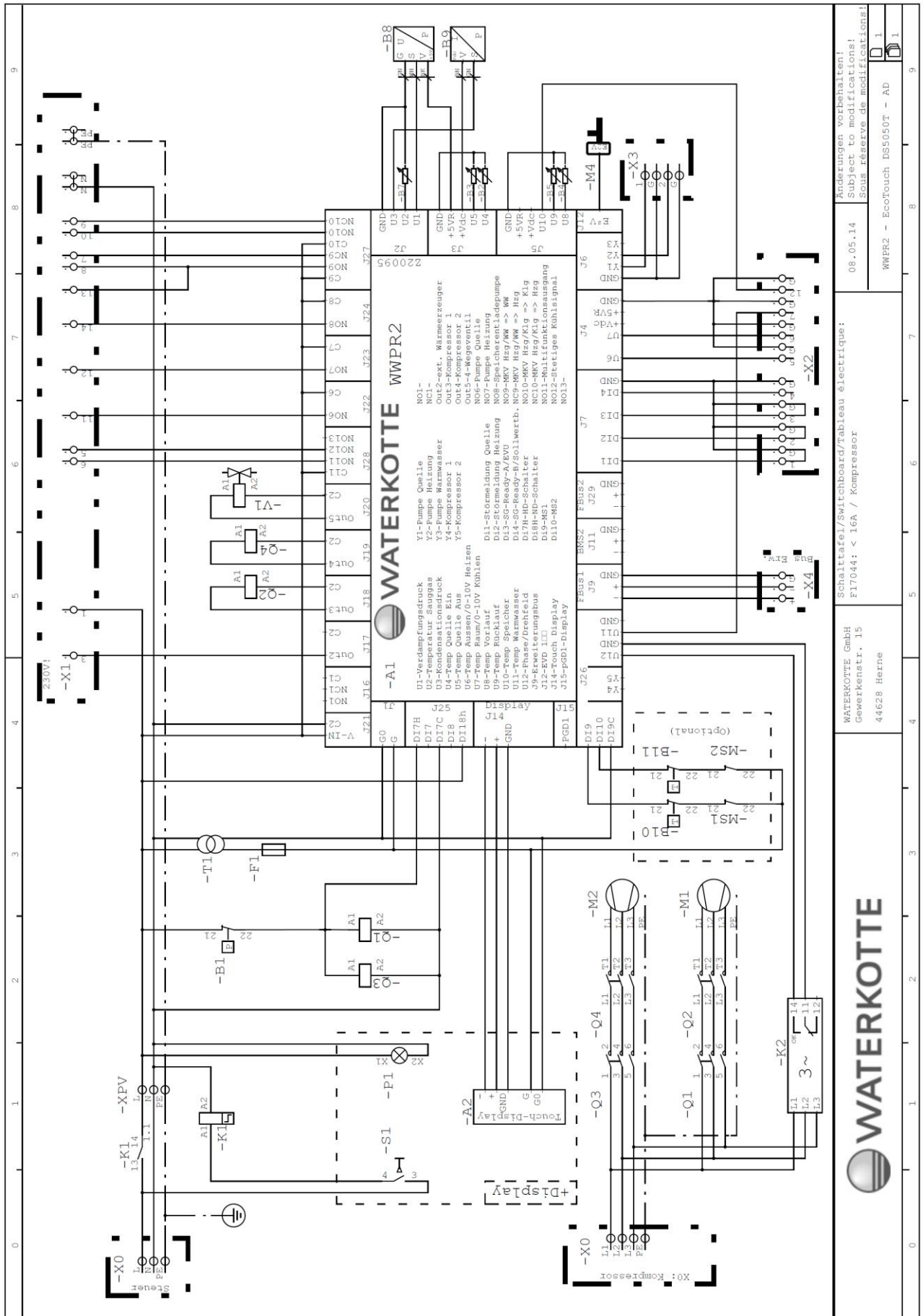

8.6 Controller WWPR 2

Deutsch	Englisch	Français
U1 – Verdampfungsdruck	U1 – Evaporation pressure	U1 – Pression évaporation
U2 – Temp. Sauggas	U2 – Temp. suction gas	U2 – Temp. gaz aspire
U3 – Kondensationsdruck	U3 – Condensation pressure	U3 – Pression condensation
U4 – Temp. Quelle Ein	U4 – Temp. source entrance	U4 – Temp. entrée captage
U5 – Temp. Quelle Aus	U5 – Temp. source exit	U5 – Temp. sortie captage
U6 – Temp. Außen / 0-10V Heizen	U6 – Temp. outdoor / 0-10V heating	U6 – Temp. exter / 0-10V chauffage
U7 – Temp. Raum / 0-10V Kühlen	U7 – Temp. room / 0-10V cooling	U7 – Temp. pièce / 0-10V rafraîchissement
U8 – Temp. Vorlauf	U8 – Temp. flow	U8 – Temp. départ chauffage
U9 – Temp. Rücklauf	U9 – Temp. return	U9 – Temp. retour chauffage
U10 – Temp. Speicher	U10 – Temp. buffer	U10 – Temp. ballon tampon
U11 – Temp. Warmwasser	U11 – Temp. hot water	U11 – Temp. ECS
U12 – Phase / Drehfeld	U12 – Phase / Rotary field	U12 – Panne phase
J9 – Erweiterungsbus	J9 – Extension bus	J9 – Bus d'extension
J12 – EVD1	J12 – EVD1	J12 – EVD1
J14 – Touch Display	J14 – Touch Display	J14 – Touch Display
J15 – pgD1-Display	J15 – pgD1-Display	J15 – pgD1-Display
Y1 – Pumpe Quelle	Y1 – Pump source	Y1 – Pompe captage
Y2 – Pumpe Heizung	Y2 – Pump heating	Y2 – Pompe chauffage
Y3 – Pumpe Warmwasser	Y3 – Pump hot water	Y3 – Pompe ECS
Y4 – Kompressor 1	Y4 – Compressor 1	Y4 – Compresseur 1
Y5 – Kompressor 2	Y5 – Compressor 2	Y5 – Compresseur 2
Di1 – Störmeldung Quelle	Di1 – Failure message source	Di1 – Message de panne captage
Di2 – Störmeldung Heizung	Di2 – Failure message heating	Di2 – Message de panne chauffage
Di3 – SG-Ready-A / EVU	Di3 – SG-Ready-A / EVU	Di3 – SG-Ready-A / Coupure externe
Di4 – SG-Ready-B / Sollwertbeeinflussung	Di4 – SG-Ready-B / Setpoint influence	Di4 – SG-Ready-B / Valeur consigne
Di7 – HD-Schalter	Di7 – HP-Switch	Di7 – Interrupteur HP
Di8 – ND-Schalter	Di8 – LP-Switch	Di8 – Interrupteur BP
Di9 – MS1	Di9 – Motor protection MS1	Di9 – Protection moteur MS1
Di10 – MS2	Di10 – Motor protection MS2	Di10 – Protection moteur MS2
NO1 –	NO1 –	NO1 –
NC1 –	NC1 –	NC1 –
Out2 – Ext. Wärmeerzeuger	Out2 – Ext. heat generator	Out2 – Producteur de chaleur ext.
Out3 – Kompressor 1	Out3 – Compressor 1	Out3 – Compresseur 1
Out4 – Kompressor 2	Out4 – Compressor 2	Out4 – Compresseur 2
Out5 – 4-Wege-Ventil	Out5 – 4-way-valve	Out5 – Vanne-4-voies
NO6 – Pumpe Quelle	NO6 – Pump source	NO6 – Pompe captage
NO7 – Pumpe Heizung	NO7 – Pump heating	NO7 – Pompe chauffage
NO8 – Speicherentladepumpe	NO8 – Buffer unloading pump	NO8 – Pompe décharge ballon
NO9 – MKV Hzg/WW => WW	NO9 – MBV Htg/HW => HW	NO9 – Vanne Ch/ECS => ECS
NC9 – MKV Hzg/WW => Hzg	NC9 – MBV Htg/HW => Htg	NC9 – Vanne Ch/ECS => Ch
NO10 – MKV Hzg/Klg => Klg	NO10 – MBV Htg/Cool => Cool	NO10 – Vanne Ch/Rafr => Rafr
NC10 – MKV Hzg/Klg => Hzg	NC10 – MBV Htg/Cool => Htg	NC10 – Vanne Ch/Rafr => Ch
NO11 – Multifunktionsausgang	NO11 – Multifunctional exit	NO11 – Sortie multifonction
NO12 – Stetiges Kühlsignal	NO12 – Continuous cooling signal	NO12 – Signal rafraîchissement constant
NO13 –	NO13 –	NO13 –

8.7 Connectors

	D	GB	F
X0 HAK			
L1	Kompressor	Compressor	Compresseur
L2	Kompressor	Compressor	Compresseur
L3	Kompressor	Compressor	Compresseur
PE	Kompressor	Compressor	Compresseur
L1	Steuerleitung	Control line	Circuit de commande
N	Steuerleitung	Control line	Circuit de commande
PE	Steuerleitung	Control line	Circuit de commande
X1 230 V			
1	230 V für externe Geräte	230 V (external devices)	230 V (appareils externes)
3	Ext. Wärmeerzeuger	External heating system	Chauffage externe
5	Kühlsignal	Cooling signal	Commande rafraîchissement
6	Sammelstörung	Collective fault	Panne collective
7	MKV:Hzg/WW=Hzg	MBV:Htg/HW=Htg	Vanne:Ch/ECS=Ch
8	MKV:Hzg/WW=WW	MBV:Htg/HW=HW	Vanne:Ch/ECS=ECS
9	MKV:Hzg/Klg=Hzg	MBV:Htg/Cool=Htg	Vanne:Ch/Rafr=Ch
10	MKV:Hzg/Klg=Klg	MBV:Htg/Cool=Cool	Vanne:Ch/Rafr=Rafr
11	Pumpe Quelle	Source pump	Circulateur source de chaleur
12	Pumpe Heizung	Heating pump	Circulateur chauffage
13	Pumpe Warmwasser	Hot water pump	Circulateur ECS
14	Speicherpumpe	Tank pump	Circulateur du ballon
N	4x Neutralleiter + 6x Neutralleiter	4x Neutral conductor - 6x Neutral conductor	4x Neutre + 6x Neutre
PE	4x Schutzleiter + 2x Schutzleiter	4x Earth conductor + 2x Earth conductor	4x Terre + 2x Terre
X2 Signale			
1	Störung: Quelle	Fault: source	Panne: source
GND	GND	GND	GND
2	Störsignal heizungsseitig (potentialfrei)	Alarm on heating side	Panne: chauffage / limiteur de température de sécurité
GND	GND	GND	GND
3	SG-Ready A, externe Abschaltung (potentialfrei)	External switch off	Coupure externe / SG Ready A
GND	GND	GND	GND
4	SG-Ready B / Sollwert-erhöhung (potentialfrei)	Setpointvalue increase	Influence externe de consigne / SG Ready B
GND	GND	GND	GND
5	Außentemperatur / 1-10 V Sollwert (Heizen)	Outdoor temperature / 1-10 V set point (heating)	Température extérieure / 1-10 V consigne (chauffage)
GND	GND	GND	GND
6	Raumtemperatur / 1-10 V Sollwert (Kühlen)	Indoor room / 1-10 V set point (cooling)	Température pièce / 1-10 V consigne (rafraîchissement)
GND	GND	GND	GND
7	Temperatur Warmwasserspeicher)	Temperature hot water tank	Température ballon ECS
GND	GND	GND	GND
12	Temp. Heizungsspeicher	Temperature buffer tank	Température ballon tampon
GND	GND	GND	GND
X3 Bus 0 - 10 V			
1	Pumpe Quelle / PWM	Source pump / PWM	Circulateur source / PWM
GND	GND	GND	GND
2	Pumpe Heizung / PWM	Heating pump / PWM	Circulateur chauffage / PWM
GND	GND	GND	GND
X4 Bus			
-	TX- (BUS-Erweiterung)	TX- (BUS expansion)	TX- (Extension de BUS)
+	TX+ (BUS-Erweiterung)	TX+ (BUS expansion)	TX+ (Extension de BUS)
GND	GND / Schirmung	GND / shield	GND / blindage

9 Pipe & instrumentation / measurement & control technology

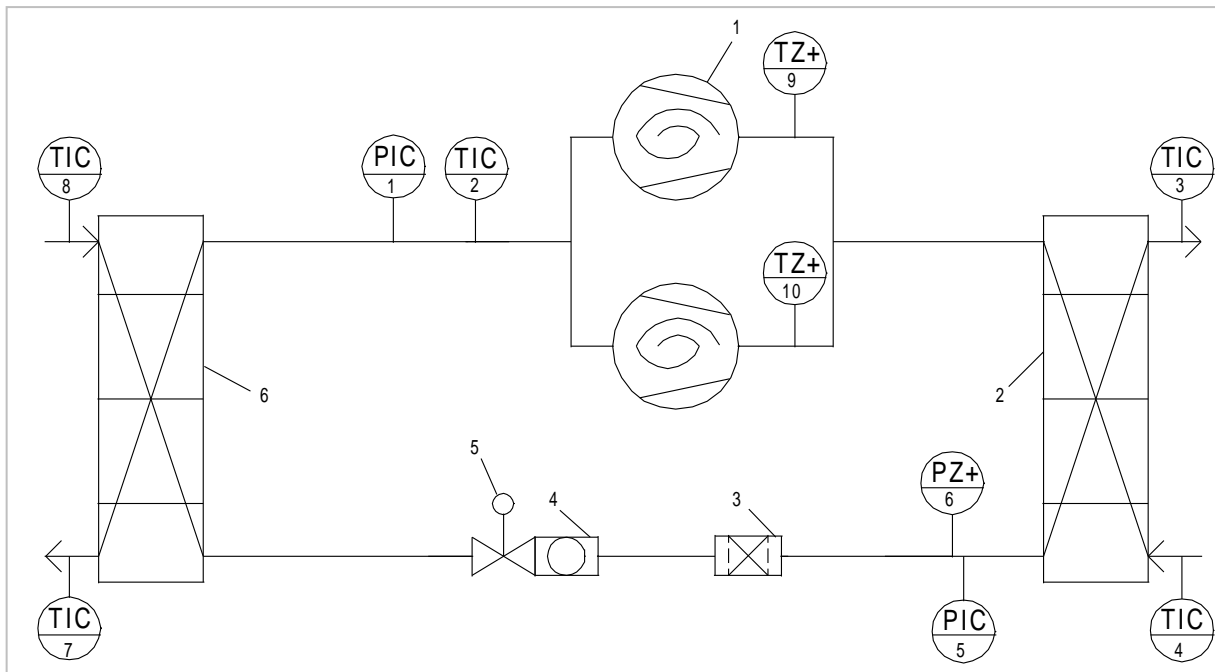

Figure 6: EcoTouch 5050T

Symbols refer to DIN 19227, page 1

No.	Instrumentation	Part
PIC/1	Measurement of pressure, readout in the controller display and control in the electrical switchboard	Pressure transmitter ND
TIC/2	Measurement of temperature, readout in the controller display and control in the electrical switchboard	NTC 10K, gauge: suction gas overheating
TIC/3	Measurement of temperature, readout in the controller display and control in the electrical switchboard	NTC 10K, gauge: condenser OUT = Heating flow
TIC/4	Measurement of temperature, readout in the controller display and control in the electrical switchboard	NTC 10K, gauge: condenser IN = heating return
PIC/5	Measurement of pressure, readout in the controller display and control in the electrical switchboard	Pressure transmitter HD
PZ+/6	Safety pressure relief valve	Safety pressure switch
TIC/7	Measurement of temperature, readout in the controller display and control in the electrical switchboard	NTC 10K, gauge: heat source OUT Vd
TIC/8	Measurement of temperature, readout in the controller display and control in the electrical switchboard	NTC 10K, gauge: heat source IN Vd
TZ+/9	Measurement of temperature: pressure gas sensor compressor 1	Pressure gas temperature sensor
TZ+/10	Measurement of temperature: pressure gas sensor compressor 2	Pressure gas temperature sensor

No.	Part	Design
1	Compressor	full hermetic scroll
2	Condenser	steel plate pack, copper soldered
3	Filter dryer	
4	Refrigerant inspection glass	
5	Expansion valve	electronic
6	Evaporator	steel plate pack, copper soldered

10 Commissioning

NOTICE

During commissioning of heat pump, anticipate the following specific risks:

Risk of total loss!

- Faulty connections can cause unexpected start-up of heat pump / uncontrolled heat pump operation.
- Mix up of connections causes motor to run in wrong direction; this could damage the heat pump.
- Incorrectly wired connections can destroy electrical / electronic components.
- Electrostatic processes / power failure can pose a risk for electronic components and also result in software errors.

To avoid damage to heat pump or injuries during commissioning of heat pump, the following points must be observed:

- Commissioning of heat pump shall only be performed by qualified persons, in compliance with safety instructions.
- Activate all safety devices and emergency-stop switches prior to commissioning.
- Check motor for correct direction the right rotary field to commissioning.
- Also read chapter 1.2.

10.1 Pre-startup checks

Before starting the heat pump, check the requirements according to the following checklist.

<input type="checkbox"/>	All electrical feed lines in the corresponding cross-sections are wired to the terminals, as per connection plan.
<input type="checkbox"/>	The push-button switch is OFF (no light).
<input type="checkbox"/>	The fuses in the fuse box are in compliance with the specifications in the connection plan (LS switch, type C for compressor feed line!).

<input type="checkbox"/>	The hydraulic connections for heat source, space heating and domestic hot water are connected.
<input type="checkbox"/>	The hydraulic systems are filled with operating media and properly vented.
<input type="checkbox"/>	Shut-off devices are open.

- When commissioning the heat pump, it is mandatory to measure the pour point of the heat source medium with a calibrated refractometer. On this basis, the minimum heat source outlet temperature must be set in the basic settings of the control. If the heat source outlet temperature is set too low (in relation to the measured pour point), the warranty and guarantee for damage caused by an insufficient pour point will be ex-

cluded. For systems that are operated without antifreeze, the minimum heat source outlet temperature must be at least +3 °C. The respective operating mode must be set in the control unit.

- Before operation, check if all plates, fuses and other protective devices are properly installed. Components that are rotating, hot or under high voltage can cause injuries.

⚠ DANGER**Warning! Risk of electric shock!**

Do not touch switch with wet hands. This poses a risk of electric shock.

⚠ DANGER**Warning! Risk of electric shock!**

The unit must be grounded. Do not connect the ground wire to gas or water lines, lightning rods or telephone grounding lines. Improperly grounded unit poses a risk of electric shock.

Connect the ground cable to the earth bar.

⚠ WARNING**Risk of injury!**

Rotating, hot, or high voltage parts can cause injury.

⚠ WARNING**Risk of injury!**

Do not touch the refrigerant pipes during operation with bare hands. The refrigerant pipes are hot or cold depending on the condition of the flowing refrigerant. When touching the tubes there is a risk of burns or frostbite.

NOTICE

Use circuit breakers with the specified capacity. If the circuit breaker capacity is larger than required, this can have a system failure or fire may result.

10.2 Initial start-up of heat pump



Figure 1: ON / OFF push-button switch (see pointing arrow)
Switch lights => Power on (normal operation))

The initial start of the heat pump is performed by a qualified WATERKOTTE system partner. After all checks have been conducted, proceed as follows:

1. Place the push-button switch and all LS switches (control voltage, compressor and electrical heating element) in position OFF (no light).
2. Place LS switch for control voltage in position ON (switching on).
3. Switch on the push-button switch (switching on).
4. Now perform controller setting according to WWPR operating manual.
5. Place LS switch for compressor in position I (switching on). Wait for compressor to start.
6. Check rotating field of compressor - with correct rotating field and voltage on all three phases, there is no message on display.
7. When the message **F016 failure phase rotating field** appears on display, check first if all three phases have voltage. If this is the case, interchange two phases at the terminal blocks in the terminal to reverse the rotating field.
8. Finally, turn ON LS switch for electric heating

NOTICE

Risk of total loss!

Repeated restart of heat pump can result in total loss!
In case of heat pump failure, an inspection by qualified and authorised personnel must be performed before restart.

Info: Controller settings must only be performed during initial start-up of heat pump.

This is not required for re-start, since the settings have been saved (settings remain saved even in case of power failure).

Info: During initial start-up, the specified limits are often exceeded, thus numerous warning messages could appear.

For this reason, the warning messages occurring during this period can be

disabled by service personnel, see *Operating manual for heat pump controller*.

After completing installation and wiring and tubing of indoor and outdoor units, check for refrigerant leaks, loose power supply or control wiring, wrong polarity, and ensure that no single phase in the power supply is disconnected.

NOTICE

The compressor will not operate unless the power supply phase connection is correct.

10.3 Control of entire operation

This heat pump is equipped with an efficient electronic control system. All necessary settings and options are described in the operating manual of the controller.

Tip: The correct use of the controller saves money. Particularly the correct settings of flow temperature, hot water temperature, heating curve and heating times can result in substantial cost savings.

10.4 Turning heat pump off

NOTICE

After finishing operation, wait at least five minutes before turning control power switch off. Otherwise, there is a risk of water leak or unit failure.

Procedure:

Push-button switch (control) of the heat pump in OFF position (no light).

Turn off LS switch: Compressor, control voltage.

10.5 Taking heat pump out of operation for extended period

- see 10.4 .

11 Troubleshooting

11.1 Possible faults and solutions

11.1.1 Fault at input side (LP fault)

- Motor protection of the source pump is activated, possibly incorrect setting.
- Faulty extraction of water or water glycol.
- Water glycol circuit insufficiently vented.
- Water glycol pour point too high.
- Evaporator contaminated, icy.
- Incorrect rotation direction of source pump.
- Refrigerant circulation interrupted (stop valve closed, filter dryer contaminated).
- Dirt trap clogged.
- Temperature of the heat source too low.
- Water in condenser too cold (below 20 °C).
- Quick temperature change in condenser.
- Insufficient refrigerant (see inspection glass).
- Incorrect setting of the controller parameter.
- Sensor incorrectly aligned or insufficiently attached.

11.1.2 Fault at output side (HP fault)

- Motor protection of the heat pump is activated, possibly incorrect setting.
- Interrupted or insufficient water circulation (possibly not enough heating circuits open).
- Hot water temperature too high.
- Air in water circuit.
- Dirt trap clogged.
- Defective circulation pump or incorrect rotation direction.
- Incorrect setting of the controller parameter.

11.1.3 Fault in circulation pumps

- Motor protection is activated.

11.1.4 Fault in compressor motor

- Overheating of motor winding; possible causes: Failure of a phase, mechanical failure due to lack of lubrication, lack of refrigerant, defects in refrigerant regulation, operation with incorrect refrigerant, excessive temperature of pressurised gas.

12 Safety measures

12.1 Pressure limits of compressor

The cooling circuit is protected against unacceptable excessive pressure by a type-tested pressostat. The switch interrupts the control voltage of the compressor contactor. Restart is locked by the central control unit and must be manually reset. **Manipulation of safety switches is prohibited and is a violation of UVV VBG20** (accident prevention regulations for cooling devices). In any case, it will result in **exclusion of warranty**.

The high pressure pressostat is placed in the pipe of the refrigerant medium at the exit of the condenser.

Shift points:

R410A 45,0 bar OFF ---35,0 bar ON

12.2 Motor protection against excessive temperature

Fully hermetic compressors are equipped with a bimetal switch that disconnects the power supply and connects again after cool down to protect against excessive motor temperatures; an error message is not generated.

12.3 Refrigerator oil

Use only the specified oil type (ester oil ICI Emkarate RL 32-3MAF); non-compliance will result in exclusion of warranty and certainly cause malfunctions.

13 Maintenance and care

We recommend annual maintenance of the heat pump. Thus you provide the reliability and efficiency of your heat pump. For more information, please contact your WATERKOTTE service partner.

In the maintenance the technical condition of the heat pump system is checked (target-actual comparison). This provides a diagnostic measurement of the thermodynamic section ensures that the efficiency is maintained on the top.

Typical inspection points

- Check heating circuit: System pressure, function of expansion tank, venting, rotation direction of pump and volume setting.
- Check water glycol circuit: Level, if necessary pressure, water glycol pour point, rotation direction of pump.
- Groundwater: Check dirt trap and clean if necessary, rotation direction of pump.
- Check cooling circuit: Screw connections, tightness, level (inspection glass), refrigerant control, diagnosis measurement log.
- Check control settings.
- Leakage test: The statutory inspection intervals are depending on the refrigerant volume. For details, see the heat pump logbook.

14 Connection diagrams

14.1 Heat pump EcoTouch 5050T with underfloor heating system, without single room control

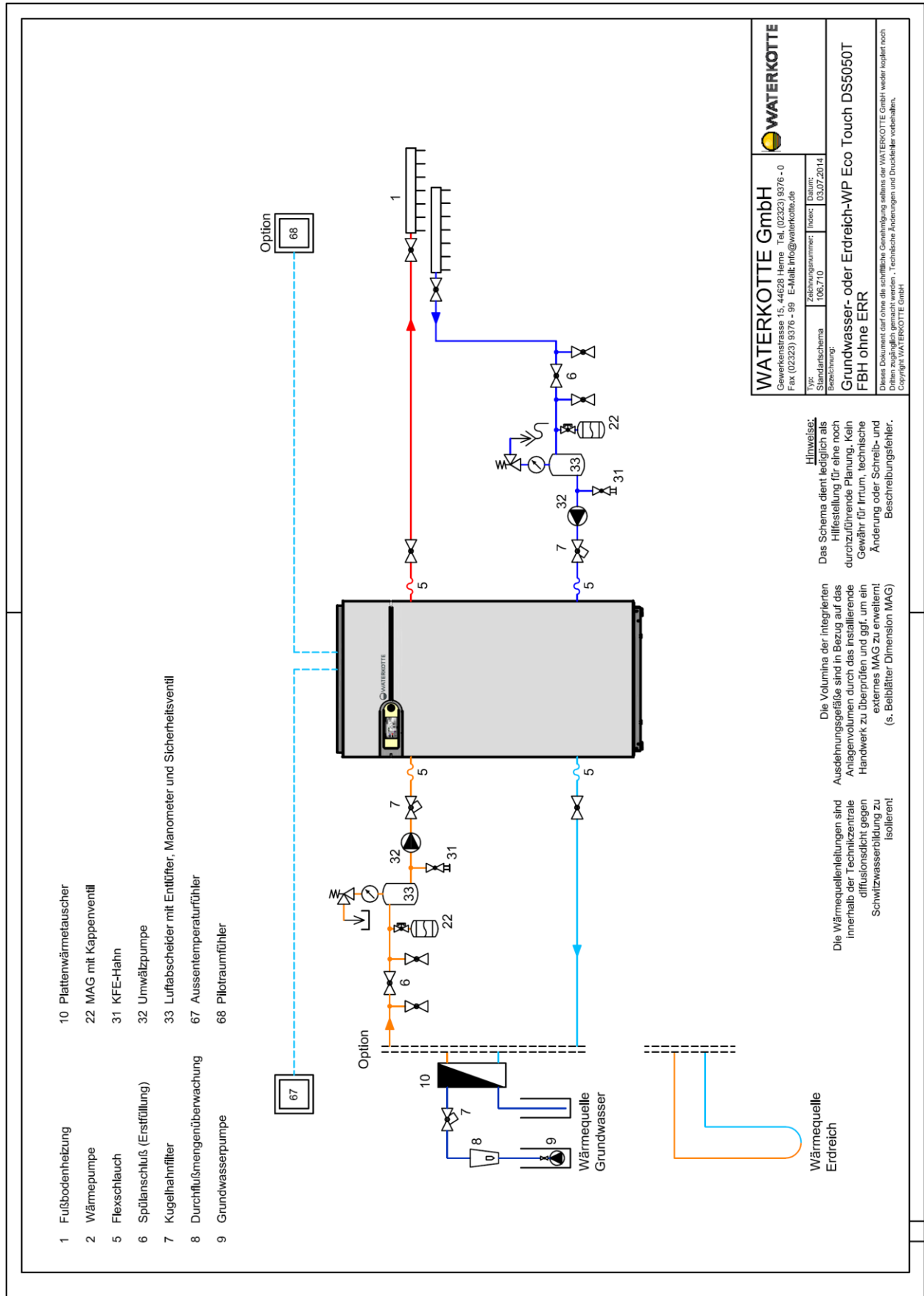

14.3 Heat pump EcoTouch 5050T with underfloor heating system, without single room control, with hygienic hot water heating

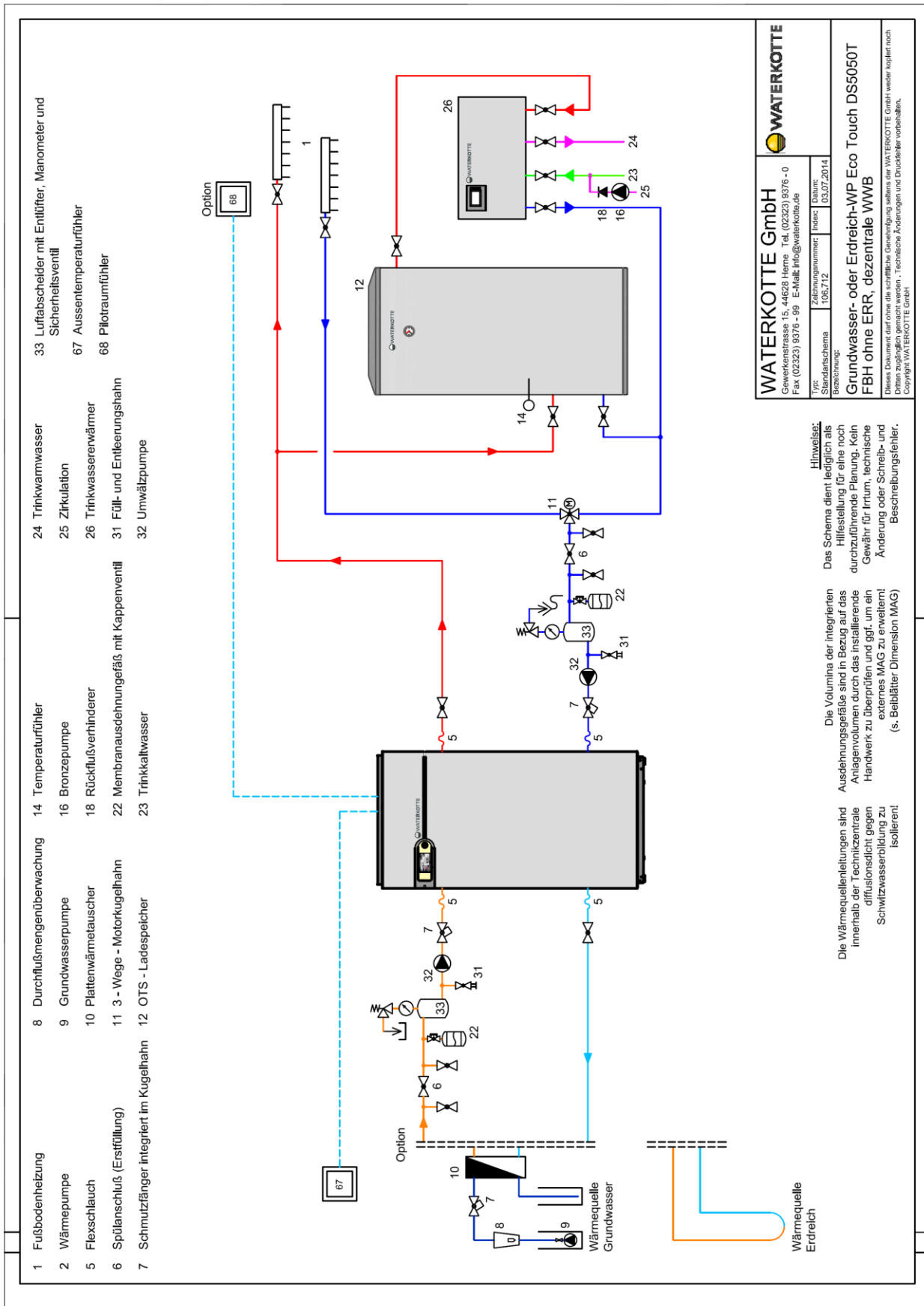

14.4 Heat pump EcoTouch 5050T ground water or ground – with connection accessory F10815 (option)

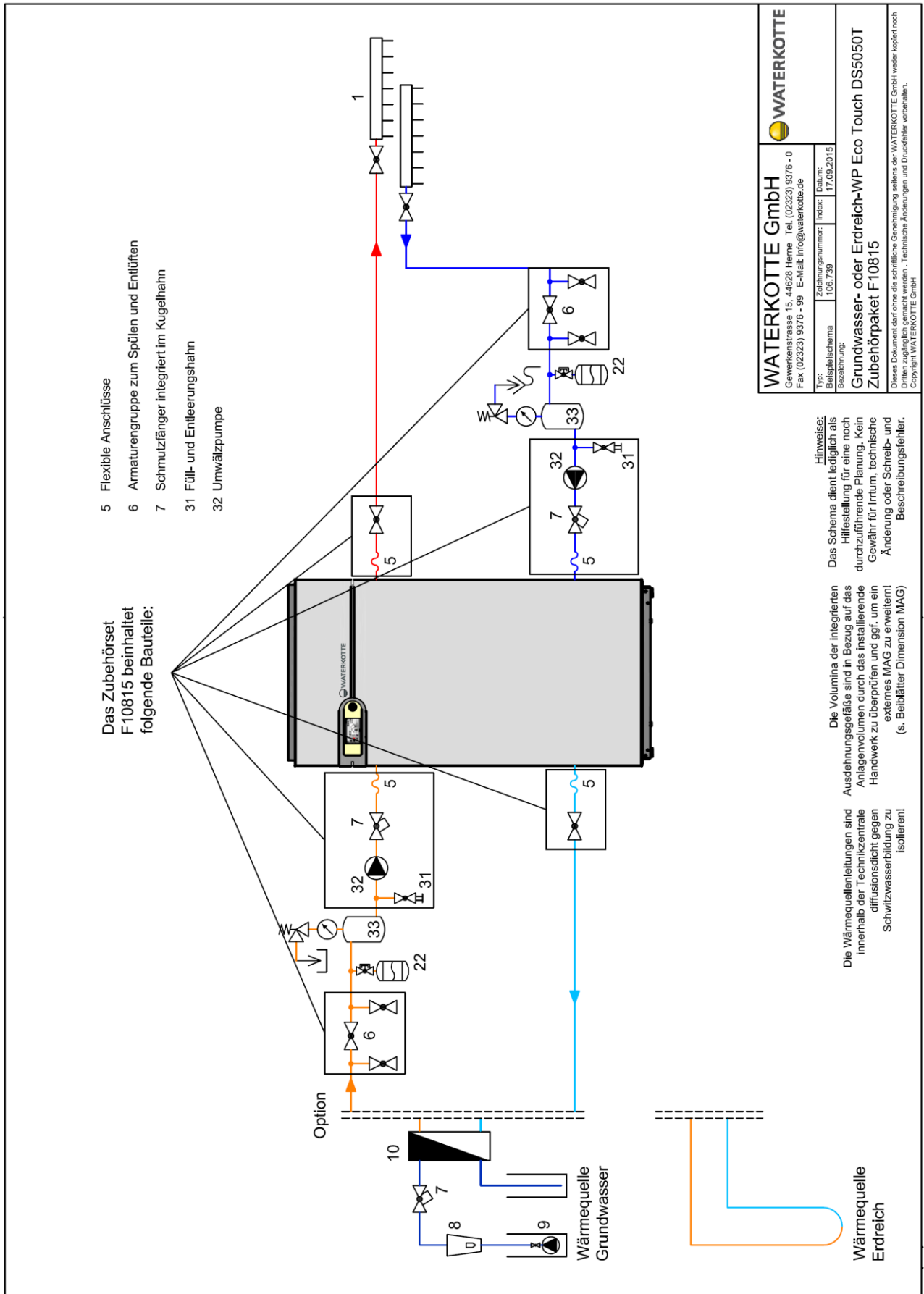

14.5 Heat pump EcoTouch 5050T ground water or ground – with connection accessory F10815 (option)

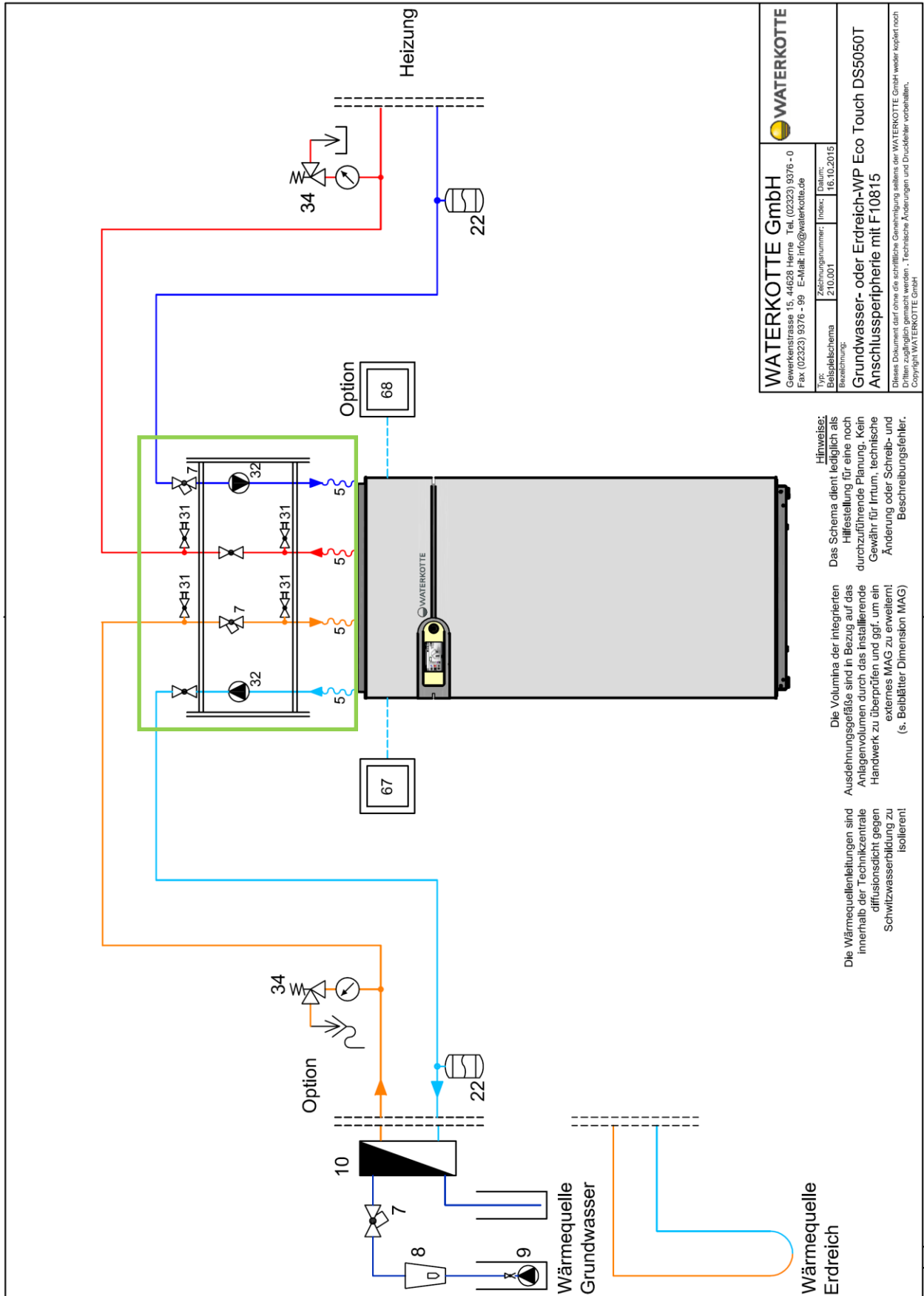

WATERKOTTE GmbH	
Gewerkenstrasse 15, 44628 Herne Tel. (02323) 9376 - 0 Fax (02323) 9376 - 99 E-Mail: info@waterkotte.de	
Typ: Beispielschema	Zichungsnummer: 210.001
Indiz:	Datum: 18.10.2015
Grundwasser- oder Erdreich-WP Eco Touch DS5050T Anschlussperipherie mit F10815	
<small>Dieses Dokument darf ohne die schriftliche Genehmigung seitens der WATERKOTTE GmbH weder kopiert noch Dritten zugänglich gemacht werden. Technische Änderungen und Druckfehler vorbehalten. Copyright WATERKOTTE GmbH</small>	

Hinweise:
Das Schema dient lediglich als Hilfestellung für eine noch durchzuführende Planung. Kein Gewähr für Irrtum, technische Änderung oder Schreib- und Beschreibungsfehler.

Die Volumina der integrierten Ausdehnungsgefäße sind in Bezug auf das Anlagenvolumen durch das installierende Handwerk zu überprüfen und ggf. um ein externes MAG zu erweitern! (s. Beiblätter Dimension MAG)

Die Wärmequellenleitungen sind innerhalb der Technikzentrale diffusionsdicht gegen Schwitzwasserbildung zu isolieren!

14.6 Description of the parts in the connection diagram

No.	Description
1	underfloor heating system
2	heat pump
3	indoor module
4	outdoor module
5	flexible connectors
6	armature group for rinsing and bleeding
7	ball valve with integrated dirt trap
8	flow rate control
9	ground water pump
10	plate heat exchanger
11	motor-powered switch ball valve (uninterruptible)
12	optimized thermo storage (charging storage)
13	optimized thermo storage (backflow array storage)
14	temperature sensor
15	radiators or convectors
16	bronze pump
17	pressure reducer
18	backflow preventer
19	relief valve
20	valve, actuating variable 1 to 2 Kelvin
21	membrane expansion tank for potable water systems
22	membrane expansion tank with shut-off fitting
23	domestic cold water
24	domestic hot water (DHW)
25	circulation
26	potable water heater
27	250 l storage for domestic hot water
28	air separator with bleeder
29	pressure bypass valve
30	pressure controlled circulation pump
31	fill and drain valve
32	circulation pump
33	air separator with bleeder, manometer and relief valve
34	safety group
35	relief valve with bleeder and manometer
36	tacosetter for hydraulic alignment
37	charging storage 250 l
38	swimming pool
039	motor-powered mixing valve
40	membrane expansion tank solar with shut-off fitting
41	heat source module
42	heat source module natural cooling
43	motor-powered switch ball valve, uninterruptible (heating and cooling)
44	2nd heat generator
45	non-return valve
46	regulating valve
47	dirt trap
48	motor-powered switch valve

No.	Description
49	motor-powered valve
50	connections integrated tube heat exchanger
51	pool heat exchanger
52	ball valve
53	optimized thermo storage with integrated tube heat exchanger
54	vertical probe
55	charging storage 1000 l – 2500 l
56	thermostatic valve
57	temperature regulator
58	gravitational brake
59	Tichelmann-hydraulics enlargement set
60	Tichelmann-hydraulics basic set
61	connection set solar
62	collector temperature sensor
63	vacuum tube
64	electronic heating element
65	charging storage 400 l with potable water heater (SET 454)
66	regulating valve
67	outdoor temperature sensor
68	reference room sensor
69	motor-powered ball valve
70	safety group with relief valve, pressure reducer, backflow preventer and membrane expansion tank with perfusion armature for potable water systems
71	215 l plastic case
72	hopper
73	immersion pipe, copper with suction strainer, non-return valve and pump connection
74	self-priming pump WJ 301 EM with 2 m cable (230 V), rated input 1100 W, connections suction-sided and pressure sided Rp1"
75	1500 mm forward flow tube with 1 1/4" cap nut with 2 seals and reducing nipple 1 1/4" x 1" a
76	1500 mm return flow tube with 1 1/4" cap nut with 2 seals
77	air separator, safety group with manometer, bleeder, relief valve, membrane expansion tank with shut-off fitting
78	motor-powered switch ball valve (potable water heating)
79	motor-powered switch ball valve (swimming pool)
80	multiple-ply filter for pool water cleaning
81	pool water - disinfection system
82	ph – value control- and adjustment system
83	pool water – drain
84	pool water circulation pump

15 Technical data

Performance table EcoTouch 5050T with R410A

	5028.5T	5034.5T	5045.5T	5056.5T
Groundwater source heating ^{1) 3)}				
Power cons./output W10/W35 ³⁾ , kW	4.4/26.8	5.9/34.1	8.1/45.2	10.1/56.4
Performance factor (COP)	6.0	5.8	5.6	5.6
Space heating energy efficiency class ⁷⁾	A+++	A+++	A+++	A+++
Efficiency class of the package of space heater ⁵⁾	A+++	A+++	A+++	A+++
Groundwater flow rate, m ³ /h (W10/W35), ΔT=3K	6.5	8.2	10.8	13.5
Pressure loss in the evaporator, mCE	1.9	2.2	2.4	2.6
Groundwater flow rate, minimum m ³ /h ²⁾ ΔT=6	3.3	4.1	5.4	6.7
Heating water flow rate, m ³ /h (W10/W35); ΔT=5K	4.6	5.9	7.8	9.7
Pressure loss in the condenser, mCE	1.2	1.2	1.3	1.4
Operating limit	W10/W65			
Heat source ground				
Power cons./output B0/W35 ³⁾ , kW	4.4/20.2	5.7/25.6	7.6/34.1	9.4/42.4
Performance factor (COP) (EN14511)	4.5	4.5	4.4	4.5
Space heating energy efficiency class	A+++	A+++	A+++	A+++
Efficiency class of the package of space heater ^{5)/}	A+++	A+++	A+++	A+++
Heat source flow rate ⁴⁾ , m ³ /h (B0/W35), ΔT=3K	5.2	6.6	8.7	10.8
Pressure loss in the evaporator, mCE (30 % ethylene glycol)	1.7	1.8	2.0	2.1
Heating water flow rate, m ³ /h (B0/W35), ΔT=5K	3.5	4.4	5.9	7.3
Pressure loss in the condenser, mCE	0.6	0.7	0.8	0.8
Operating limit	B-5/W60 . B0/W65			
Compressor	tandem-scroll			
1.compressor: sound power level EN12102 at B0/W35 dB(A)	53.0	55.0	57.0	54.0
2.compressor: sound power level EN12102 at B0/W35 dB(A)	58.0	60.0	62.0	59.0
1.compressor: sound power level EN12102 at B0/W55 dB(A)	53.0	55.0	57.0	54.0
2.compressor: sound power level EN12102 at B0/W55 dB(A)	58.0	60.0	62.0	59.0
Electrical data 3 x 400 V, 50 Hz				
Compressor	400 V, 3~, 50 Hz			
Starting current, A	51.5	62.0	75.0	102.0
Starting current soft start, A (standard)	26.0	31.0	38.0	51.0
Max. operating current, A	2x 7.4	2x 9.7	2x 13.0	2x 15.3
Main fuse, provided by customer, delay A	C 20 A	C 25 A	C 32 A	C32 A
Control fuse, provided by customer, delay A	B 10 A	B 10 A	B 10 A	B 10 A
Dimension, weights, connections				
Number of scroll compressors	2	2	2	2
Compressor volume oil filling (l)	2x1.24	2x 1.24	2x 1.89	2x 1.77
Refrigerant volume R410A (kg)	3.65	4,0	5,0	5,6
Minimum volume, installation room, ref. to EN 378-1 (m ³)	8.3	--	--	--
Weight of device (kg)	221	232	265	286
Connections: Heat source / use	R2" ext.			
Dimensions W x H x D, mm	750x1470x611			

¹⁾ Heat source ground water with intermediate circuit. For details refer to our product range. The energy rates are basing on this system configuration. ²⁾ W10/W35 and Δt=6K. ³⁾ Tolerances stated in EN 12900 and EN14511 apply for the performance data listed above. ⁴⁾ Heat source (70 % water + 30 % ethylene glycol). ⁵⁾ When the composite label Waterkotte WWPR controller class III was considered (without room temperature sensor). ⁷⁾ Seasonal space heating energy efficiency class under average climate conditions - medium-temperature application (55 °C).

WATERKOTTE GmbH, Gewerkenstraße 15, D-44628 Herne

Tel.: 0049/(0)2323/9376-0, Fax: 0049/(0)2323/9376-99

Service: 0049/(0)2323/9376-350

E-Mail: info@waterkotte.de, Internet: <http://www.waterkotte.de>